



Crusader Power Scythes

Manufactured by BCS S.p.A.

Models 615L • 615SL • 630



Operating Instructions

Before commissioning the machine, read operating instructions and observe warning and safety instructions.

**PLEASE ALSO READ ORIGINAL
BCS INSTRUCTION MANUAL**



 **TRACMASTER**
The landscape machinery specialists

Contents

Page 3	Safety
Page 4	Controls - 615L
Page 5	Controls - 615SL
Page 6	Controls - 630
Page 7	Identification & Stickers
Page 9	Setting Up The Scythe Cutter Bar
Page 11	Types of Transmission & Cutter Bars
Page 12	Identifying Controls
Page 13	Instructions for Use
Page 16	Attaching Scythe to Power Unit
Page 17	Operating Hints
Page 18	Starting the Engine
	Operation
Page 19	Stopping the Engine
Page 20	Useful Information
Page 21	Maintenance Guide
Page 23	Risk Assessment
Page 24	Troubleshooting
Page 25	Sound & Vibration Levels
Page 26	Spare Parts
Page 27	Manufacturer Information



IMPORTANT

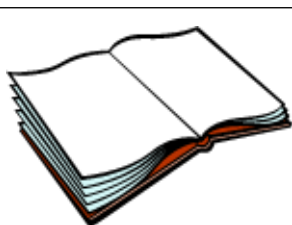

READ CAREFULLY

No liability will be accepted for any damage caused to persons or property through failure to observe the operating and safety instructions.

Safety

ALWAYS read the original manufacturer's manual first

ALWAYS start the engine in the open air

DO NOT smoke when refuelling

DO NOT mix OIL with the fuel

ALWAYS stop the engine before making any adjustments, refuelling, moving or cleaning, or when the unit is unattended

USE ONLY fuel from containers designed for this purpose - refuel outdoors only and replace the tank cap securely

IN CASE of petrol spillage move the machine away from the area of spillage and allow the petrol vapours to dissipate before starting the engine

DO NOT remove any safety guards that are fitted

DO NOT touch any moving parts or attempt any maintenance whilst the machine is running - **KEEP HANDS AND FEET AWAY**

BEFORE starting work clear the work area of any objects that could damage the machine

DO NOT allow children or anyone uninstructed to operate the machine - **KEEP ANIMALS AWAY**

DO NOT use on slopes or banks of more than 20°

ALWAYS wear suitable clothing to give personal protection including footwear that offers a good grip

AVOID wearing loose garments that may catch in moving parts

KNOW how to stop the machine in an emergency

NEVER interfere with any control settings on the engine

NEVER select reverse gear with your back to a wall or other immovable object

IF A FAULT develops **DO NOT** attempt any repair - immediately contact the supplier from whom the machine was obtained

VISUALLY INSPECT the machine before use - ensure all blades, nuts and bolts are tight and not worn or damaged and replace blades if necessary

KEEP IN MIND the operator is responsible for accidents or hazards occurring to people or property

Controls



Controls



Controls Description

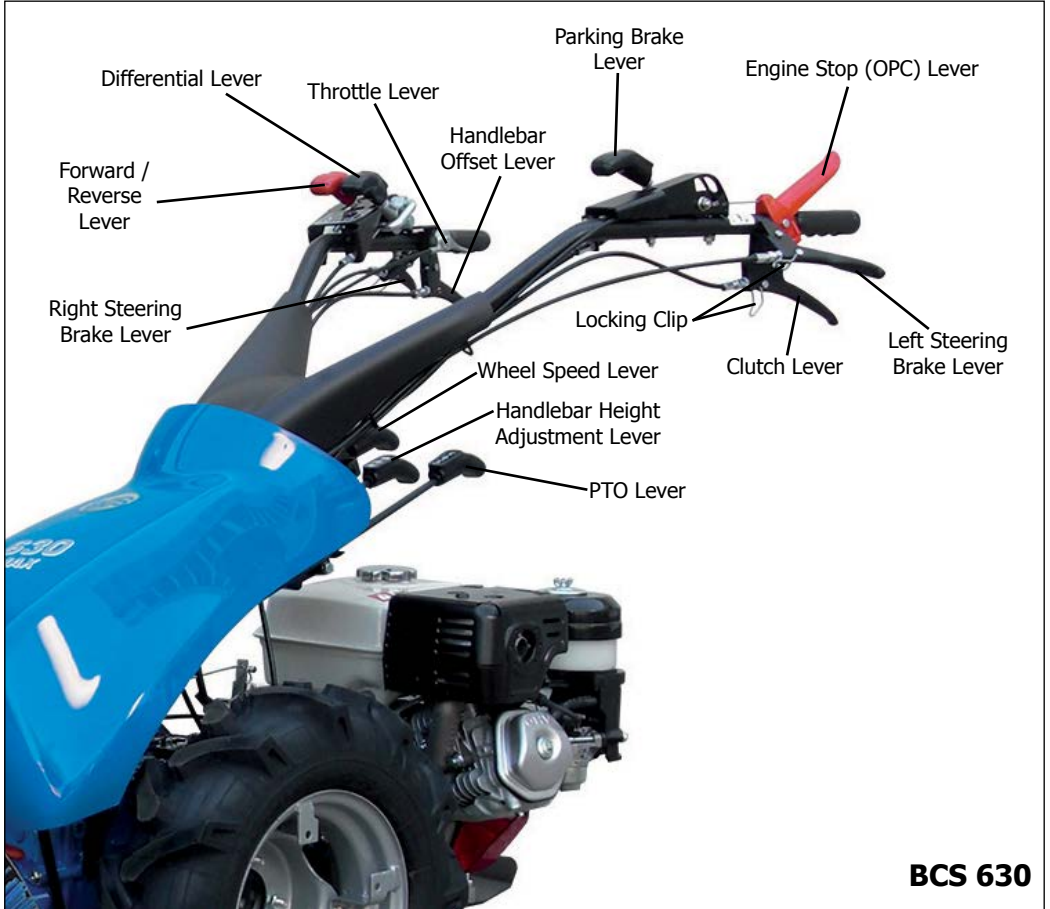

Identification and Stickers

An identification sticker is applied to every machine, as well as product certification in accordance with the EC Machine Directive (fig.2/1).

NOTE: The weight value indicated on the identification plate only refers to the transmission. In order to obtain the overall weight of the sickle bar, it is necessary to add the weight of the cutter bar which has been chosen for coupling.

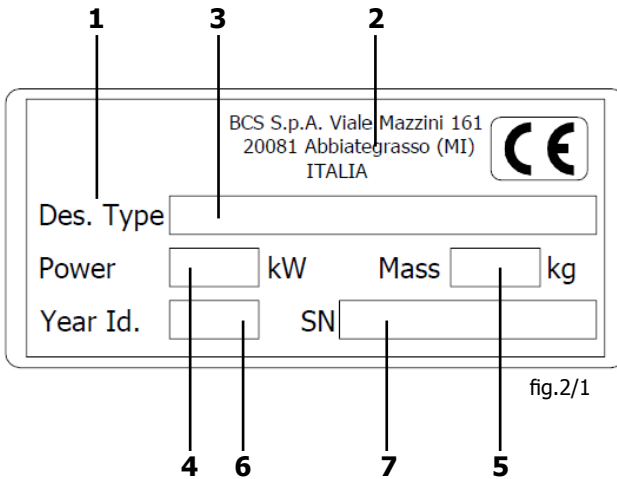

1. Brand
2. Manufacturer
3. Model
4. Minimum Power Required
5. Weight (see note above)
6. Identification Number of Production Year
7. Serial Number

Preservation of the Labels

IMPORTANT! The labels must be kept clean from dust and mud, must always be clearly visible and legible, and must be replaced if missing or illegible.

If any of the components have to be replaced and they were originally equipped with a safety label, it is important that the component is returned to its original condition complete with new labels.

The labels are available as spare parts and can be obtained from your supplier. The part numbers for each sticker can be found on the parts diagram specific to each machine model, and are normally also printed on the label.

Identification and Stickers

1

BCS S.p.A. Viale Mazzini 161
20081 Abbiategrasso (MI)
ITALIA

CE

Des. Type

Power kW Mass kg

Year Id. SN

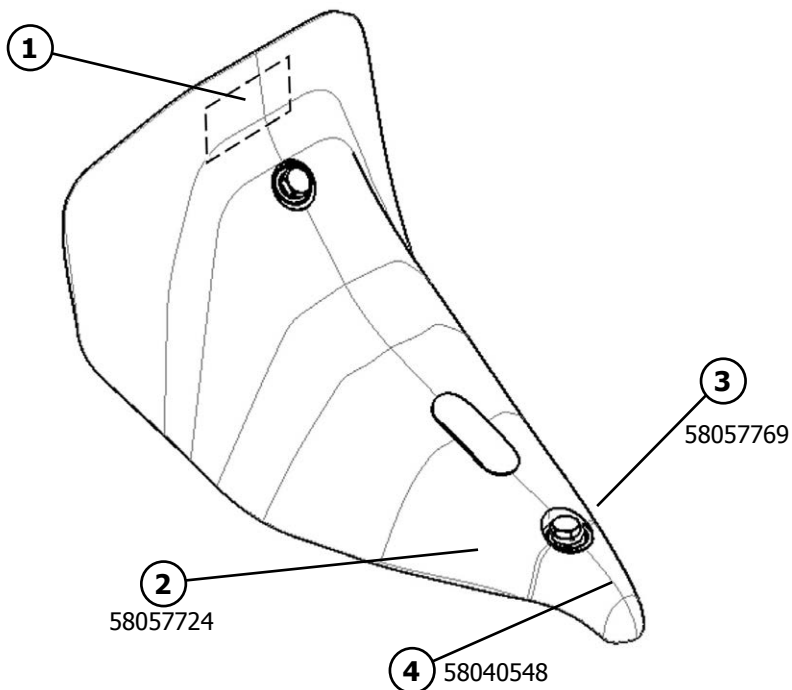
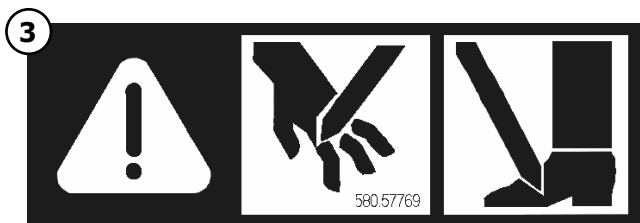

Setting Up The Scythe Cutter Bar

What the Machine is Designed For

The scythe cutter bar is designed for mowing grass and pastures by cutting stems at the base.

This is achieved by coupling the gearbox or transmission (power unit) to the cutter bar attachment which consists of the cutting blades.

Opening the Boxes

The scythe attachment is delivered in two boxes, one containing the transmission and the other containing the cutter bar.

These should be moved either with a forklift truck or carried by at least two people. Open the boxes starting from the lid, and remove the accessories.

Preliminary Checks

Check that the machine is in good condition and has not been damaged in transit, then proceed with assembly as indicated in the following points.

WARNING! Protective gloves must be worn for all assembly operations, repair and use (fig.4/1).

Gearbox Assembly

Fix the protection cover A to crank B as shown in fig.4/2.

NB: For dry transmission and short oil bath transmissions two C spacers must be used, for long oil bath transmissions only one C spacer is required, and for DUPLEX transmissions no spacers are required.

Fix the rear side of the protection cover A to the transmission, as shown in fig.4/3 and fig.4/4, according to the type of transmission and gearbox.

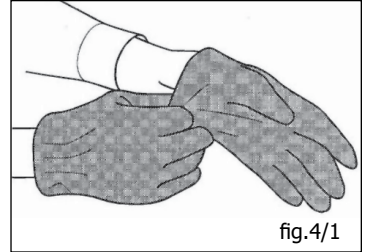

fig.4/1

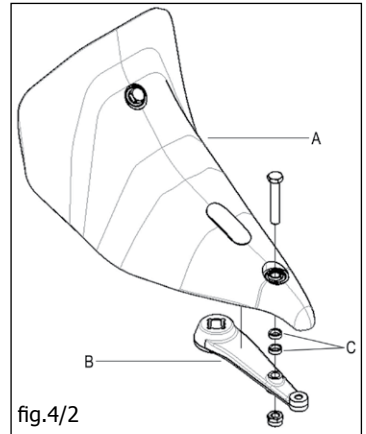

fig.4/2

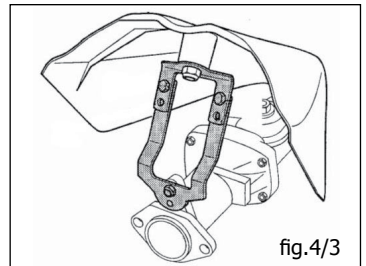

fig.4/3

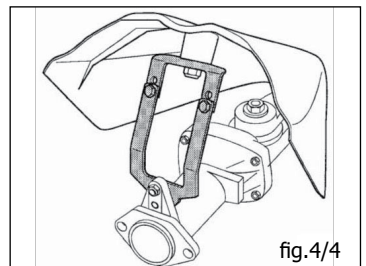

fig.4/4

Setting Up The Scythe Cutter Bar

Fixing Cutter Bar to Transmission

Lay the cutter bar flat and remove the two nuts A and related washers (fig.4/5).

Move the transmission closer to the cutter bar making sure that the pivot is correctly lodged, then mount the cutter bar B to control panel A using the two nuts and washers (fig.4/6) and tighten securely.

NB: For the assembly of the DUPLEX bars (with a double crank mechanism), ensure both pins F and G fit into their housings (fig.4/7), then proceed as described above.

IF A HIGH CUT IS NECESSARY: Install the cutting height adjustment slides (skids) C on the cutter bar using the bolts provided (fig.4/8).

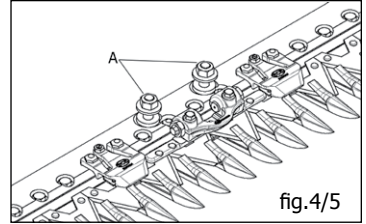

fig.4/5

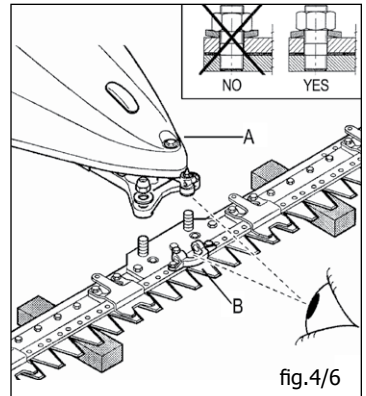

fig.4/6

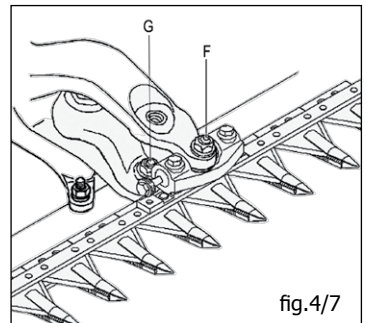

fig.4/7

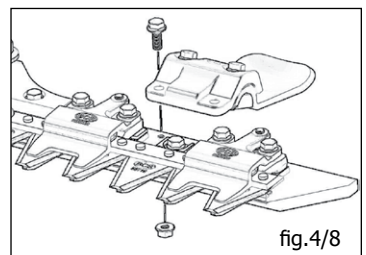

fig.4/8

Types of Transmission and Cutter Bars

Types of Transmission

1. Dry transmission, with ordinary maintenance and grease lubrication.
2. Low maintenance oil bath transmission, available in long and short versions.
3. Reciprocating movement and oil bath transmission, for DUPLEX cutter bars.

Types of Cutter Bar

1. Laser cutter bars (widths available 80 - 100 - 115 - 135 - 155 - 175cm).

These anti-clogging bars are recommended for tangled, tough and fine grass typical of mountainsides. The perfect "scissor cut" is enhanced by the high quality of the materials.

Also available with a spring-steel blade-holder to reduce adjustments, improve cutting and performance. It should not be used on uncultivated and stony land.

2. Cutter bar with fingers (widths available 115 - 145cm). These have the traditional fingers which protect the blade and work very well on grass in general and for haymaking.

Due to the characteristics of the fingers, they should not be used when grass is thick, fine or tangled, due to clogging problems.

3. DUPLEX bars with reciprocating movement and oil bath transmission (widths available 120 - 150 - 180cm).

These have traditional fingers and self-adjusting spring-steel blade-holder which assure constant pressure. Efficient and effective in every working condition, they never clog and offer a high quality cut even at high speed.

Identifying Controls

1. Regulating screws for coupling blade (fig.5/1)
2. Regulating screws for blade holders (LASER bars and FINGERS bars) (fig.5/2)
3. Crank drive group greasers (fig.5/3)
4. Blade control pin greasers (DUPLEX) (fig.5/4)
5. Oil replacement and discharge plug (oil-bath crank drive) (fig.5/5)
6. Blade protection (fig.5/6)
7. Flanging (fig.5/7 – 5/8)
8. Coupling blade (fig.5/1)

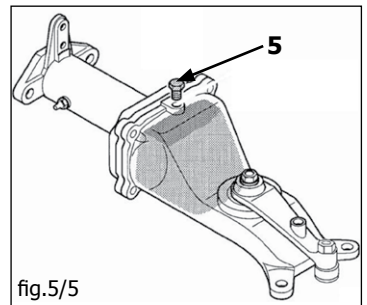
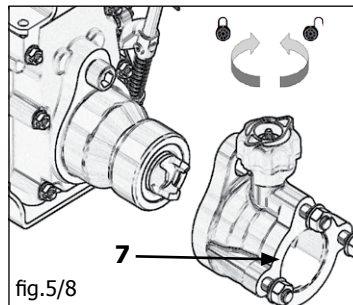
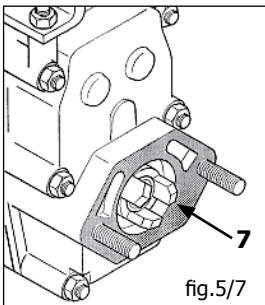
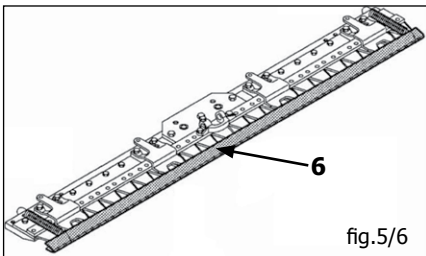
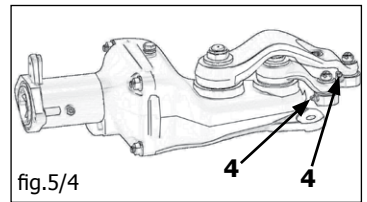
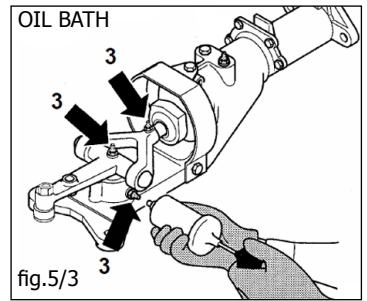
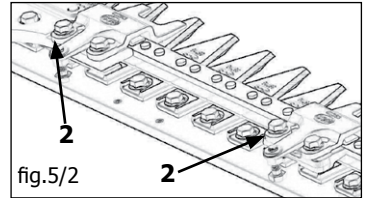
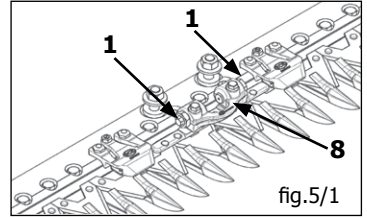

Instructions for Use

Operator Training

Warning! The machine has been designed for the use indicated on page 6. It is strictly forbidden to use it for any other purposes (eg. transporting persons, as a trailer, any type of racing, run on public roads, etc). It must not be changed nor tampered with.

Warning! Do not put your hands or feet near the work zones or moving or rotating parts.

Warning! Before using the machine, you must familiarise yourself with the controls. Learn how to turn off the engine safely and quickly, always read the safety instructions.

Warning! Do not allow the use of the machine to minors, to non-experts, do not carry passengers, do not operate near channels or docks that can collapse under the weight of the machine.

Caution! Whilst using the machine it is important that the operator uses appropriate personal protective equipment (PPE) safety shoes, ear protections, goggles, gloves, etc.

Do not attempt any cleaning or maintenance operations to the machine or parts of the implement without observing the safety instructions contained in this manual, and in the specific manual to each implement.

Before you switch on the machine, you must know the devices and safety features and controls.

Checks Prior to Starting the Machine

- Check that in oil-bath transmission, the oil is at a certain level (fig.13/2).
- Check that the gearstick of the engine unit is in neutral.
- Check that the PTO of the engine unit is in neutral.
- Check that the implements are clean and free from impediments.

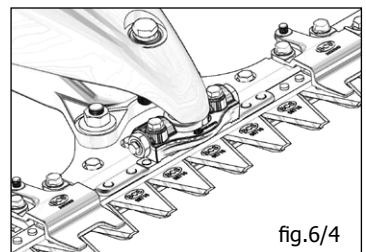
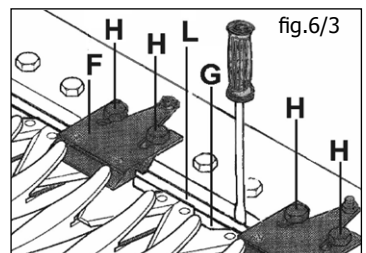
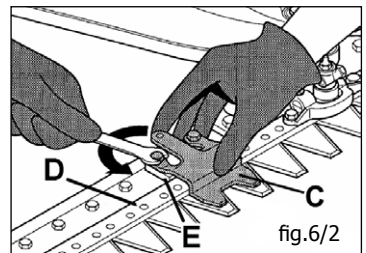
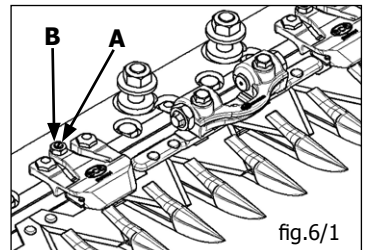
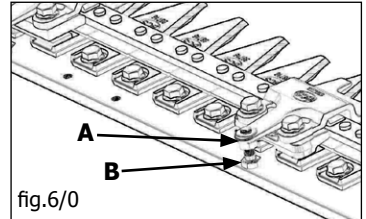

Instructions for Use

Blade Holder Adjustment

There are three types of blade pressing bars suitable for:

1. LASER bar
2. Cutter bar with FINGERS
3. DUPLEX and LASER ELASTO bars

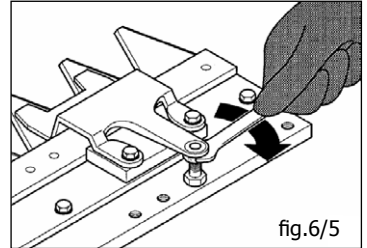

1. Blade holder adjustment for LASER cutter bar

Loosen the upper lock nut A (fig.6/0). Adjust the tension screw B until the blade slides freely between the tooth and blade holder without excessive slack.

When the adjustment produces the best motion without binding, tighten the upper lock nut A.

2. Blade holder adjustment for cutter bars with FINGERS

Loosen the upper lock nut A (fig.6/1). Adjust the tension screw B until the blade slides freely between the tooth and blade holder without excessive slack. When the adjustment produces the best motion without binding, tighten the upper lock nut A.

3. The spring-steel blade-holders of the DUPLEX and LASER ELASTO bars do not require any adjustment.

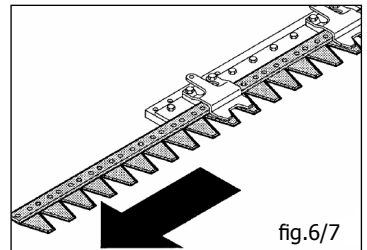
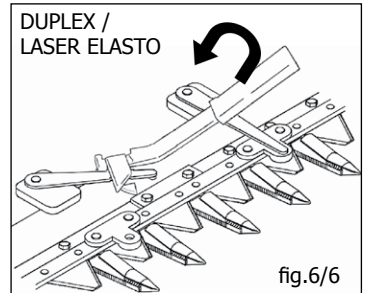

Blade Adjustment

To adjust the LASER bar, loosen the blade-holder C (fig.6/2), position the blade on the wear blocks E on the blade holder, and then tighten the bolts allowing a little slack.

For the bar with FINGERS, loosen the screws H on the blade-clamping devices F (fig.6/3), and using a screwdriver draw the blade guide L closer to the blade bar G, leaving a space of 0.1/0.5mm between them. Then tighten the screws H on the blade-clamping devices once again.

The DUPLEX and LASER ELASTO bars do not require blade adjustments.

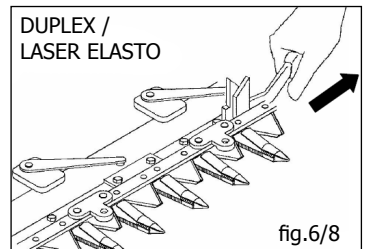

Instructions for Use

Blade Replacement

All types of blades are replaced by loosening the bolts and removing the blade holder (fig.6/4).

If necessary loosen the blade holder (fig.6/5 and 6/6) and remove the blade (fig.6/7 and 6/8).

FOR BLADE ADJUSTMENT SEE PREVIOUS PARAGRAPH.

Replacement of Traction Pin

Every 100 work hours check the condition of the blade control pin A, and the ferrule B (fig.6/9).

If replacement is required, loosen the block nut C then slide out the pin A and the ferrule B, then replace them with new parts.

Check the setting screw G (fig.6/10) that fixes the steel blade M, and replace if necessary.

Tighten the V screws completely on the steel blade. Tighten each G setting screw to the same degree until almost all the play has been eliminated on the blade control pin (fig.6/11) and then block them with conic lock nut D.

NB: The DUPLEX has two pins A, and two bushes B.

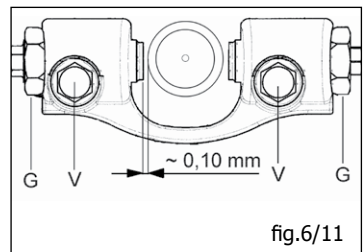
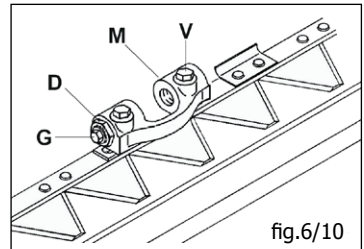
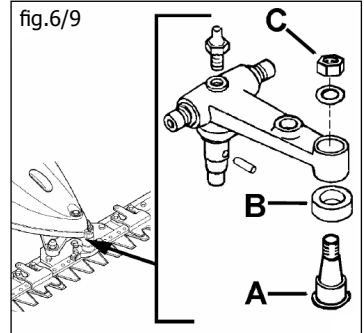

Attaching to Power Unit

Attention! For all assembly and repair operations, always wear heavy work gloves to protect your hands.

Fitting to models: 615L - 615SL - 630 - 630WS - 710 - 728 - 738 - 740

If fitted, remove the PTO cover plate, remove the nuts, washers and cover plate (fig.7/1) and then attach the scythe cutter bar to the tractor unit (fig.7/2 A) using the previously removed nuts and washers.

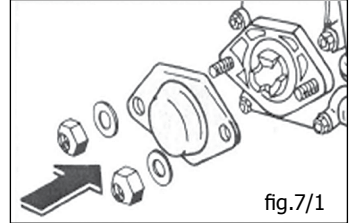

If using implement quick release, fix the implement coupler to the scythe cutter bar (fig.7/3 C). It is important that nuts (fig.7/3 D) which fasten the implement and the bushing are well tightened.

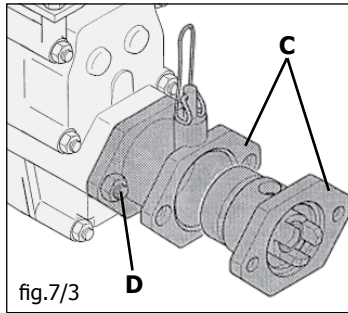
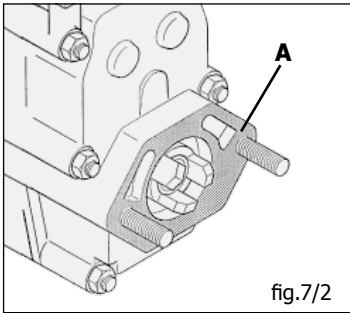

Fitting to models: 660 - 750

The scythe cutter bar is mounted directly to the machine coupler (fig.7/4 A) by attaching the coupler (fig.7/5 C) that is fixed to the scythe.

The fitting and removal of attachments is achieved by rotating the knob (fig.7/5 R). The device is locked by turning the knob clockwise and unlocked by the knob anti-clockwise. It is important that nuts (fig.7/5 D) which fasten the implement and the bushing are well tightened.

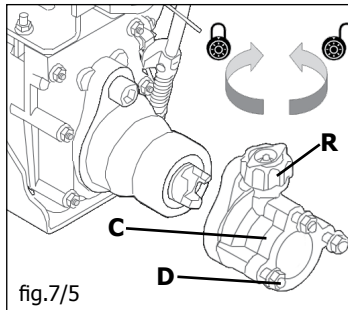
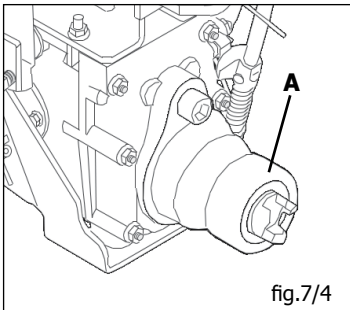

Operating Hints

During transportation of the machine, or when it is not in use, install the blade guard on the bar.

Always wear heavy gloves to protect your hands whilst working on the equipment.

Read and observe all warning labels on the machine and implements.

Always wear appropriate work clothes whilst operating the machine, always wear safety footwear.

Do not use the machine near children or animals.

The machine operator is responsible for any damage to persons or property.

Always walk with the machine - do not run.

Never work on slopes of more than 20° and always work across the face of a slope (side to side), never up and down. Never use the machine on a bank where there is a possibility of the machine sliding down the slope.

Always disengage the power take-off (PTO) when changing direction or location of operation.

Do not replace the blades or attempt to undertake any maintenance of the cutter bar while the engine is running.

Only qualified persons should operate the machine.

IMPORTANT: Read all machine and implement manuals thoroughly before using the cutter bar.

Always familiarise yourself with the machine's operation before commencing work.

Best results are obtained with the engine at a low throttle setting, which enables the bar to cut cleanly and gives less wear and tear on the reciprocating parts, which in turn reduces maintenance.

On rough terrain, the bar should be raised by the height adjuster skids to prevent the blades from digging into the ground (see fig.4/8 on page 7).

Read the owner's manual before starting using the cutter bar.

After starting the engine, position the accelerator at minimum power, pull the clutch handle and engage the power take-off. Release the clutch and observe the normal operation of the machine. Pull the clutch again engage the desired gear, release the clutch and begin normal operation.

Do not engage too high gears as these can be dangerous.

Familiarise with the machine and its commands before starting operation.

WARNING: If any abnormal vibrations or sounds occur, STOP the engine immediately and check the machine and the cutter bar. If you have any concerns contact your supplier.

Starting the Engine

Check the engine oil level. Top up with 10w/40 oil if necessary.

Check fuel level. Only use unleaded petrol from a clean container.

Never re-fuel when the engine is hot or running.

Leave 1" air space in the fuel tank.

Depress the red Engine Stop (OPC) Lever then pull up the Clutch Lever and secure with the Locking Clip.

Ensure the Wheel Speed Lever is in neutral 'O' position.

Set the Throttle Lever to half.

Turn the fuel tap on the engine to 'ON' position, if the engine is cold set the choke lever to 'ON' position.

Pull the recoil start handle gently until it engages then give it a good strong pull to start the engine.

When the engine has started, release the choke lever after a few seconds and return the Throttle Lever to idle position.



IMPORTANT

**NEVER USE MORE THAN 1/4 THROTTLE
WHEN THE CUTTER BAR IS OPERATING**

Operation

Use the Handlebar Height Adjustment Lever to set handlebar height.

Pull up the Clutch Lever. This will automatically release the lever Locking Clip.

Ensure the red Forward/Reverse Lever is in the correct position to move forward: if the handlebars are positioned over the engine then this lever should be in the fully back position.

Engage drive to the cutter bar by using the PTO Lever: if the handlebars are positioned over the engine then pull the PTO Lever towards you.

Using the Wheel Speed Lever, select 1st gear.

Raise the throttle slightly, release the Clutch Lever gently and fully, keeping the red Engine Stop (OPC) Lever depressed as the engine will stop if this is released.

Commence work.



IMPORTANT! NEVER USE MORE THAN ¼ THROTTLE WHEN THE CUTTER BAR IS OPERATING

Stopping the Engine

Close the Throttle.

Pull up the Clutch Lever.

Locate the Wheel Speed Lever in neutral position.

Disengage drive to the cutter bar by using the PTO Lever (push the PTO Lever away from you).

Release Clutch Lever.

Release red Engine Stop (OPC) Lever completely.

WARNING: THE EXHAUST COVER MAY BE HOT - DO NOT TOUCH

Useful Information

General

The scythe cutter bar is the ideal tool for cutting grass in general, both in orchards and vineyards, and on agricultural land in general.

The transmission of movement from the power take-off to the actual cutting equipment itself occurs by means of a highly resistant steel shaft and a crankshaft (two in the case of the DUPLEX) lubricated with an oil bath.

Cutting speed must be evaluated each time, depending on the type of product being used and on the type and conditions of the terrain being worked on.

IMPORTANT: Check the terrain before proceeding to work, in order to ensure there are no stones, sticks, irrigation pipes or foreign bodies.

Cleaning

To keep the machine in good working order it is recommended that cleaning is carried out daily and that dust, mud, leaves, dry or encrusted grass, etc is removed.

Pressure washing machines removes lubricating grease as well as dirt. It is imperative all linkages are kept well greased otherwise they will become difficult to operate and cause damage.

DO NOT turn the machine on its side for cleaning.

Storage and Prolonged Inactivity

Clean grass and mud off the bar carefully and then lubricate the bar to avoid oxidation. Use an old paintbrush or similar to smear grease over the cutter blades.

Let the machine run for a few minutes, then return the machine to a dry environment, sheltered against bad weather and, if possible, cover it with a cloth.

If storing the machine for a prolonged period (over one month), it is recommended that the petrol be drained from the carburettor and fuel tank, or a fuel stabiliser added to prevent the petrol becoming stale and ineffective.

Movement and Transport

If the machine must be lifted up, it is recommended that it is placed on pallets, appropriately secured, and lifted using fork-lift trucks.

Maintenance Guide

Engine Maintenance

For detailed engine maintenance please refer to engine manufacturers manual.

After every hour of operation stop the engine and remove the spark plug cap.

Check engine oil level (recommended oil SAE 10w/40). Before checking the oil level ensure the machine is level.

Remove the gearbox unit dipstick and ensure the oil reaches the top level mark, if necessary top up with the recommended gear oil for the specific power unit (see Power Unit Owner's Manual for more details).

Replace the spark plug cap.

Cutter Bar Maintenance

Every 8 work hours, grease the drive unit at the lubrication points (fig.5/3).

The blade control pivots of the DUPLEX gearbox must be greased every 8 hours (fig.13/1).

The oil bath control units contain 1 litre of oil for the normal unit and 1.4 litres for the DUPLEX unit. They do not require greasing just periodic checks to ensure correct oil levels.

To check the oil level remove the oscillating safety device then remove the oil plug (fig.13/2 A).

For LASER units the oil should be 60mm below the hole, and for DUPLEX units it should be approximately 40mm below the hole. If the oil level is too low, top up with SAE 80W/90 oil (fig.13/2).

Ensure the cutter bar blades are clean and sharp at all times. After each use wash the cutter bar to remove any grass or soil and check the sharpness of the blades.

After washing lubricate the blade to avoid oxidation. Use an old paintbrush or similar to smear grease over the cutter blades.

Check to ensure all nuts and bolts are well fastened, including those securing the bar to the drive unit and machine implement.

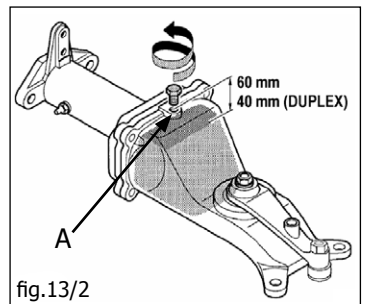
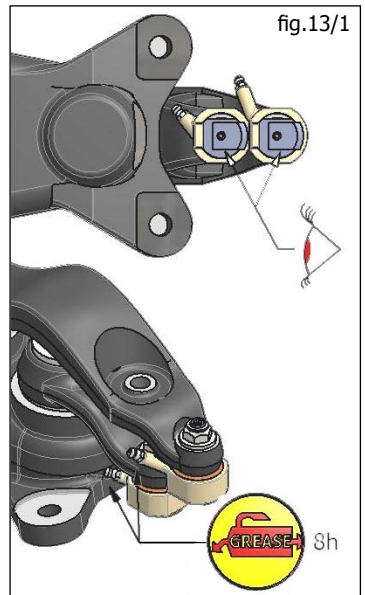
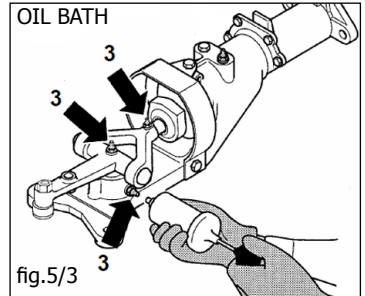

Maintenance Guide

	OPERATION	EVERY DAY	EVERY WEEK	EVERY MONTH	EVERY 6 MONTHS	EVERY 12 MONTHS
Engine	Check engine oil level 10w/40 See separate engine manual	X	X			
Gearbox & Controls	Check gearbox oil level EP90	X	X			
	Check nuts & bolts	X	X			
	Ensure clutch cable has free play		X			
	Check tyre pressure (20psi)		X	X		
	Lubricate control cable/linkages		X			
	Check control cable operation		X			
	Check operation of safety devices		X			
	Change gearbox oil EP90					X
	Grease gear speed detent ball		X	X		
Scythe Cutter Bar	Lubricate blades	X				
	Check for loose bolts			X		

- * Pressure washing machines removes lubricating grease as well as dirt. It is imperative all linkages, especially the gear speed lever detent ball, are kept well greased otherwise they will become difficult to operate and cause damage.
- * DO NOT turn the machine on its side for cleaning.
- * Before storing machine always leave the Clutch Lever pulled in and secured with the Locking Clip to prevent sticking of the clutch plates.
- * DO NOT allow maximum engine speed to exceed 3600rpm.

Risk Assessment

HAZARDS	RISK LEVEL	ACTION NEEDED
Machine tipping over	Low	Do not use on slopes over 25°. Work across slopes, never up and down.
Machine running away	Low	Operator presence control (see Power Unit manual) stops the machine driving if the operator releases the handlebars. Always check operation before use.
Lacerations	High	Remove the spark plug cap before carrying out any maintenance or cleaning. Always wear gloves when cleaning or lubricating the cutter bar blades.
Machine reversing and trapping the operator against an immovable object	High	Never reverse the machine with your back to a wall or similar object.
Burns	High	Be very careful of a hot exhaust. Turn off the machine before re-fuelling. Allow 1" air space in fuel tank.
Flying objects	Low	Never exceed ¼ throttle when mowing.
Foot injuries	High	Never let anyone stand in front of the machine when it is operating. Keep all pets and animals away.
Handlebar adjustment	Low	Always set the height and sideways position before operating the machine – never while it is moving.

Troubleshooting Guide

PROBLEMS	POSSIBLE CAUSES	SOLUTIONS
When the PTO is turned on the cutter bar does not work or only works intermittently.	The clutch cable has not been adjusted.	Adjust clutch cable play.
	Issues preventing the PTO from being activated.	Activate the PTO properly.
	PTO electrical connections are damaged.	Replace the electrical connections.
Excessive vibration during operation.	The engine has high revs, above 3400'/min.	Adjust the engine revs.
	The accelerator is being used beyond $\frac{3}{4}$ of its limit.	Lower the accelerator's rpm.
	Unsuitable or old fuel is being used.	Use fresh and suitable fuel.
	The blade attachment has not been adjusted.	Adjust play to 0.1mm.
	The engine is not revving properly.	Clean or replace the air filter.
		Clean the carburettor, spark plug or injector.
	Insufficient or lack of greasing.	Grease as shown in the manual.
	Too much play between pivot and bush.	Parts are worn, replace them.
	Bush / pivot have not been lubricated as shown.	Lubricate as shown in manual.
	Loose nuts on PTO flange.	Tighten the PTO nuts well.
	Loose screws and nuts in general.	Check and tighten well.
	Scythe attachment is too light (power unit is engine-heavy).	Add cutter bar weights or implement extension.
	Unriveted blades.	Rivet and replace if necessary.
	Broken fingers.	Replace the fingers.
	Worn transmission bearings.	Check and replace if necessary.
Loose crank nut.	Tighten the nut well.	
Worn crankshaft.	Replace the crankshaft.	
When going downhill grass is not emptied.	Excessive downhill slope.	Where required for your own safety, avoid cutting on excessive downhill / uphill slopes.
Going uphill the machine loses grip.	Excessive uphill slope.	

Troubleshooting Guide

PROBLEMS	POSSIBLE CAUSES	SOLUTIONS
Bad cut.	Blunt blade.	Sharpen or replace blade.
	Sections of blade broken.	Replace broken sections.
	Spring-steel blade holder not adjusted.	Adjust spring-steel blade holder as shown in the manual.
	Cutting progress speed too high.	Reduce cutting progress speed.
	Excessively flattened grass.	Change cutting entry direction.
	Excessively wet grass.	Let it dry out.
	Terrain is not flat.	Change direction of cutting progress.

Sound & Vibration Levels

Power Unit	Petrol Engine			Diesel Engine		
	LAeq (1)	LwA (2)	m/sec ² (3)	LAeq (1)	LwA (2)	m/sec ² (3)
615L MAX	89.8	105.2	32.39	n/a	n/a	n/a
615SL MAX	89.8	105.2	32.39	n/a	n/a	n/a
630 MAX	99.6	106.4	33.31	n/a	n/a	n/a

(1) LAeq - ACOUSTIC PRESSURE: values expressed in equivalent dB(A).

(2) LwA - ACOUSTIC POWER: values expressed in dB(A).

(3) m/sec² - VIBRATION: average square value calculated at handlebars according to UNI EN 12733.

Spare Parts

When ordering spare parts please ensure you provide the complete part number as listed in the spare parts diagrams.

Diagrams can be downloaded from our website at www.tracmaster.co.uk/pages/parts-diagrams or obtained by contacting our Spare Parts Department.

If you need to order replacement blades then it is important that you quote the following information:

- The number that is engraved on the top of each tooth.
- The number of blades on your complete top bar.
- The serial number of the scythe cutter bar.

The serial number of the implement should also be quoted, this can be found on a label on the underside of the blue cowling.

Complete the boxes below to record this information and have it to hand when ordering parts.

To order parts contact our Spare Parts Department by phone on 01444 247689 or email spares@tracmaster.co.uk.

Number of Blades on Top Bar:

Number Imprinted on Blades:

Scythe Cutter Bar Serial Number:



Number Imprinted on Blades

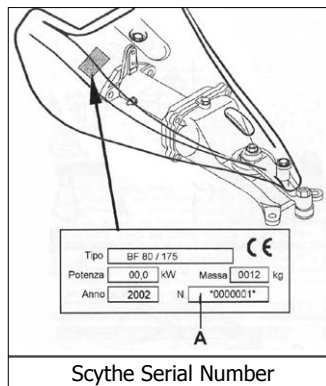

Scythe Serial Number

Manufacturer Information

This machine is manufactured in Italy by BCS S.p.A.

Tracmaster Ltd is the UK distributor for these models, the BCS Laser Scythe Cutter Bars.

BCS S.p.A. has been at the forefront of developing cutting edge agricultural machinery since its formation in 1943, when their founder developed a self-propelled motor mower. Tracmaster Ltd has been the UK distributor for BCS pedestrian equipment since 1984.

Please ensure you read the original manufacturer's manual before operating this machine.



BCS S.p.A.

V.le Mazzini, 161
20081 Abbiategrasso (MI)
Italy

Tel: +39 02 9482 1

Fax: +39 02 9496 0800

Email: info@bcs-ferrari.it

Website: www.bcsagri.it

© Tracmaster Ltd 2017.
Specifications are subject to change without prior notice.



Tracmaster Ltd, Sovereign Centre, Victoria Road, Burgess Hill RH15 9LR
T: +44 (0) 1444 247689 F: +44 (0) 1444 871612
W: www.tracmaster.co.uk E: info@tracmaster.co.uk