

## Optional Extras

---

### Optional Extras (500 Series only)

Sprung Drawbar  
6mm floor and 4mm sides  
Tipping stabiliser kit – 12 – 16 tonne

### Optional Extras (Euro series only)

8 Tonne Drop Side (one side only)  
8 Tonne Swing Drawbar  
Hydraulic folding side  
Top hinge door only - manual latches less  
Top hinge door only c/w side hinging & storage bracket  
Aluminium ramps c/w storage and rear door as per option  
Steel ramps c/w storage and rear door as per option  
Two Way Tip  
Removable Rear Bale Rack

### Optional Extras (All Dump Trailers)

10 Stud Axles on 12 Tonne  
420 x 180 High Speed Axles  
Rear Steering axle (18 and 20 tonne)  
Tandem axle on sprung bogie or tandem spring complete with adjustable hitch (12 – 16 tonne)  
10mm floor  
12mm floor  
6mm hardox floor in lieu of standard  
8mm hardox floor in lieu of standard  
6mm sides  
8mm sides  
Hardox body, 6mm floor, 4mm sides, 6mm door  
Hardox body, like for like

### TYRES

445 x 65 x 22.5 tyre  
560 x 60 x 22.5 radial tyre  
Other options available on request

### BRAKES

Dual Air/Hydraulic brakes  
Air only brakes  
Hydraulic brakes load sensing - only available on trailers with suspension  
Air brakes load sensing - only available on trailers with suspension  
Cable operated breakaway system  
Trailer to ROI standard c/w cable operated system  
NC Electric operated breakaway system  
12v ABS complete with Susie  
24v ABS complete with Susie

### Other

Steel toolbox  
Plastic toolbox  
Weld on stone guard  
Bolt on stone guard  
8" Extension Sides (Bolt On)  
8" Timber Extension Sides  
Weight transfer Rams  
Adjustable Hitch  
Swivel Hitch  
Weld-on spoon type K80 in lieu of standard  
Bolt-on spoon type K80 in lieu of standard  
Bolt-on 50mm agri in lieu of standard  
.Rear Tow Hitch c/w Light socket  
Folding Rear Tow Hitch c/w Light Socket  
Hydraulic Jack  
Number plate light  
Long vehicle signs (legal requirement for tractor & trailer 13m + in ROI)  
Flashing beacon  
L.E.D. Control Kit  
Side marker lights



NC Engineering (Hamiltonsbawn) Ltd  
2 Killyrudden Road  
Hamiltonsbawn  
Co. Armagh  
Northern Ireland  
BT61 9SF

Tel: 028 38 871970  
Fax: 028 38 870362

[www.nc-engineering.com](http://www.nc-engineering.com)





# Dump Trailer Range



[www.nc-engineering.com](http://www.nc-engineering.com)

- Available in 10 – 15 tonne carrying capacities
- Patented tail- door design enables the Dump Trailer to be used with or without the tail-door in operation. without the need for hydraulics
- Side panels manufactured from 5mm thick steel and supported by a continuous horizontal bulge bar to ensure excellent strength to weight ratio
- Body pivot hinge designed to ensure maximum height of discharge. Higher pivot point for easy stockpiling
- Wider and lower construction for better stability and ease of loading with rubber tyred or mini track excavators
- Body can be scraped clean using 6ft (1.8m) bucket



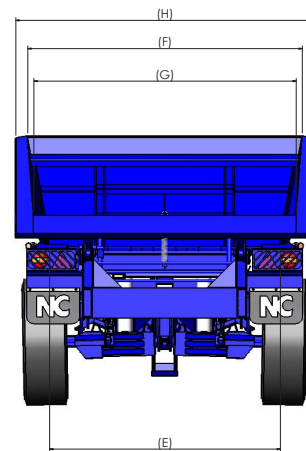
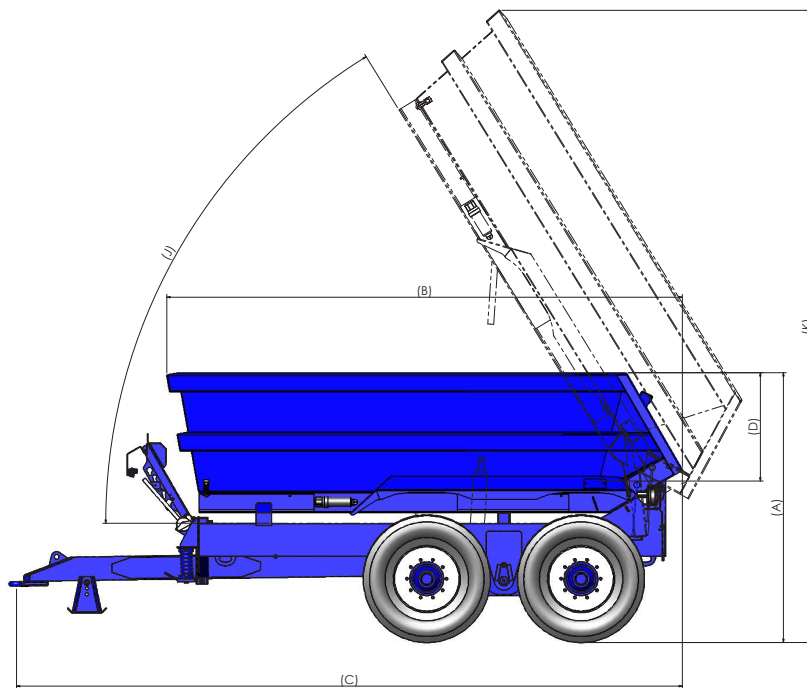

**300 Series**

	310 10T	312 12T	314 14T	316 16T	318 18T	320 20T	320 20T BC	325 25T (Air)
Overall Height (A)	1.93	2.03	2.10	2.22	2.24	2.34	2.34	2.40
Body Length (B)	3.73	4.00	4.14	4.16	4.56	4.56	4.56	5.78
Overall Length ©	5.10	5.40	5.54	5.54	5.94	5.94	5.94	7.22
Floor to top of side (D)	0.67	0.74	0.82	0.92	0.92	1.02	1.02	1.03
Width of floor (E)	1.83	2.00	2.00	2.00	2.00	2.00	2.00	2.00
Inside body width at top side (F)	2.06	2.26	2.28	2.32	2.32	2.36	2.36	2.37
Inside body width at bottom side (G)	1.83	2.00	2.00	2.00	2.00	2.00	2.00	2.00
Overall width (H)	2.23	2.43	2.45	2.52	2.52	2.56	2.56	2.54
Tipping Angle (J)	77	73	73	73	72.5	72.5	72.5	64.5
Max height when tipped (K)	5.12	5.45	5.49	5.58	6.00	6.00	6.00	6.81
Number of axles	2	2	2	2	2	2	2	3
Floor Thickness	8.00	8.00	8.00	8.00	8.00	8.00	8.00	8.00
Wall Thickness	5.00	5.00	5.00	5.00	5.00	5.00	5.00	5.00
Volume	4.30	5.70	6.30	7.20	8.00	9.00	10.10	11.20
Draw Bar	Sprung	Sprung	Sprung	Sprung	Sprung	Sprung	Sprung	Sprung
Axles	80mm 8 Stud	80mm 8 Stud	90mm 10 Stud	120mm 10 Stud	120mm 10 Stud	120mm 10 Stud	120mm 10 Stud	127mm 10 Stud
HYD Brakes	350x60	350x60	400x80	400x80	420x180	420x180	420x180	420x180
Slack Adjusters	No	No	Yes	Yes	Yes	Yes	Yes	Yes
Tyres	385x65x22.5	385x65x22.5	385x65x22.5	385x65x22.5	18rx20	445x65x22.5	445x65x22.5	445x65x22.5